

# S8387

NL

Bedankt voor de aanschaf van dit product.

Bij eventuele schade of problemen, vragen wij u onze website **www.solid.eu/sav** te raadplegen en de procedure te volgen die op onze website uitgelegd wordt. Als u niet in de mogelijkheid bent om via het web de aanvraag te doen, vragen wij u te begeven naar de winkel waar u uw constructie heeft gekocht, samen met de beschadigde stukken (of met een foto) en met het **SAV** document, terug te vinden in het montageplan, zodat een eerste controle door de winkel uitgevoerd kan worden. Vergeet ook niet de barcode (beginnend met PO) mee te nemen of ze te vermelden op het **SAV** document op de voorziene plaats. U kan deze terug vinden op het etiket op de verpakking van de constructie ofwel op de leveringsbon. (zie uitleg hieronder) Al deze zaken zijn onontbeerlijk en dus noodzakelijk voor de behandeling van uw klacht.

ES

Gracias por la compra de este producto.

En caso de eventuales daños o problemas, les rogamos de visitar en enlace internet **www.solid.eu/sav** y seguir el procedimiento indicado en dicho pagina web. Si no fuese posible dirigirse al internet, les aconsejamos dirigirse a la tienda donde adquirió el producto, junto con los materiales dañados (o con una foto) y el documento **SAV**, que se encuentra en el plano de montaje, a fin de que en la tienda se pueda realizar el primer control. No olvide llevar el código de barras a continuación (comienza con las letras PO) y mencionarlo en el lugar correspondiente en el documento **SAV**. Puede encontrar el código en la etiqueta, pegada al embalaje de la construcción, o tambien en el albarán. (vean explicaciones aqui debajo) Todos estos asuntos son indispensables, y por lo tanto, necesario para el tratamiento de su queja.

F

Nous tenons à vous remercier pour l'acquisition de ce produit.

En cas de problèmes ou de dégâts, nous vous invitons à vous rendre sur le lien internet suivant **www.solid.eu/sav** et à suivre la procédure indiquée sur la page web. S'il ne vous est pas possible de vous rendre sur internet, il vous est demandé de prendre contact avec le magasin où vous avez acheté votre produit, muni des pièces défectueuses (ou d'une photo) et du document **SAV** figurant dans le plan de montage, afin qu'un premier contrôle puisse être effectué par le magasin. Veuillez transmettre le code barres (commençant par **PO**), ou le mentionner dans votre document SAV à l'endroit indiqué. Vous le trouverez sur l'étiquette de l'emballage de votre produit ou sur le bon de livraison (voir explication ci-dessous). Ces données sont indispensables au traitement de votre réclamation.

P

Obrigado por ter comprado este produto.

Em caso de problemas, convidamos você a visitar o nosso website **www.solid.eu/sav** e seguir o procedimento. Quando você não tem acesso à internet, faça favor de ir à loja onde comprou o seu produto junto com as peças avariada (ou uma fotografia) e com o documento **SAV**, que se encontra no plano de montagem, de maneira que o primeiro controle possa ser feito pela loja. É importante que leve consigo o código de barras indicado (que começa por PO) ou mencioná-lo no documento **SAV** no lugar apropriado. Pode encontrá-lo na etiqueta na embalagem do produto ou na ordem de entrega. (veja explicação na parte inferior) Todas estas coisas são indispensáveis para assegurar um pronto atendimento da sua queixa.

GB

Thank you for acquiring this product.

In case of problems or damages please visit our website **www.solid.eu/sav** and follow the instructions. If not possible to access our webpage by internet please contact the shop where the product was bought, provided with the flawed parts (or with a picture) and the **After Sale Service** document enclosed in the assembly plan, so that the shop can carry out a first control. Also communicate the following bar code (beginning with PO) or mention it in your **After Sale Service** document in the field provided. You can locate the bar code on the label fixed on the packaging or on the delivery order. (explained below) information is needed in order to handle your claim.

D

Vielen Dank für den Kauf dieses Produkt.

Bitte wenden Sie sich bei eventuellen Beschädigungen oder Problemen an unsere website **www.solid.eu/sav** und folgen sie unseren Website. Wenn Sie nicht in der möglichkeit die Anforderung über das internet zu machen, bitte wenden Sie sich an den Händler, bei dem Sie Ihr Produkt gekauft haben, und nehmen Sie die beschädigten Teile (oder ein Foto davon) sowie das **SAV**-Dokument, das Sie im Montageplan finden, mit, sodass ihr Händler das Problem untersuchen kann. Bitte denken Sie auch an unten stehenden Barcode (beginnend mit PO). Nehmen Sie diesen ebenfalls mit oder geben Sie ihn an der dafür vorgesehenen Stelle auf dem **SAV**-Dokument an. Sie können diese zurück finden auf das Etiket von der Verpackung der Konstruktion oder auf der Lieferschein (siehe Erklärung unten) Oben genannte Informationen und Dokumente sind für die Bearbeitung Ihrer Beschwerde notwendig.

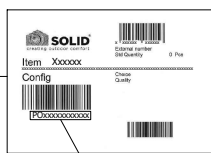
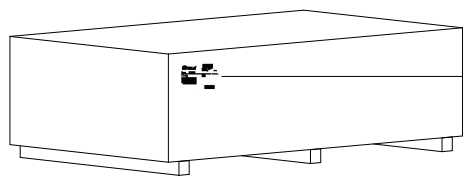

- (GB) Sticker
- (NL) Sticker
- (F) Autocollant
- (D) Aufkleber



- (GB) Delivery note
- (NL) Leveringsbon
- (F) Bon de livraison
- (D) Lieferbeleg

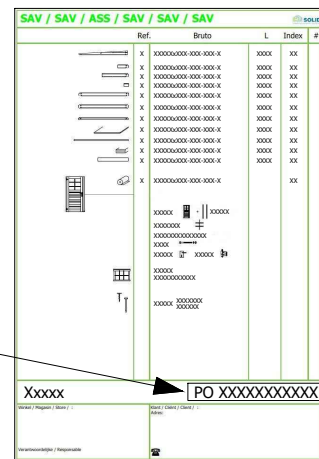

n° PO xxxxxxxxxxxx

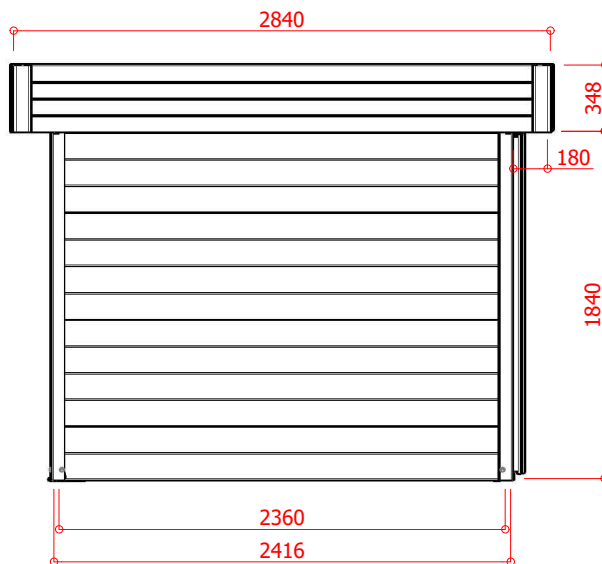
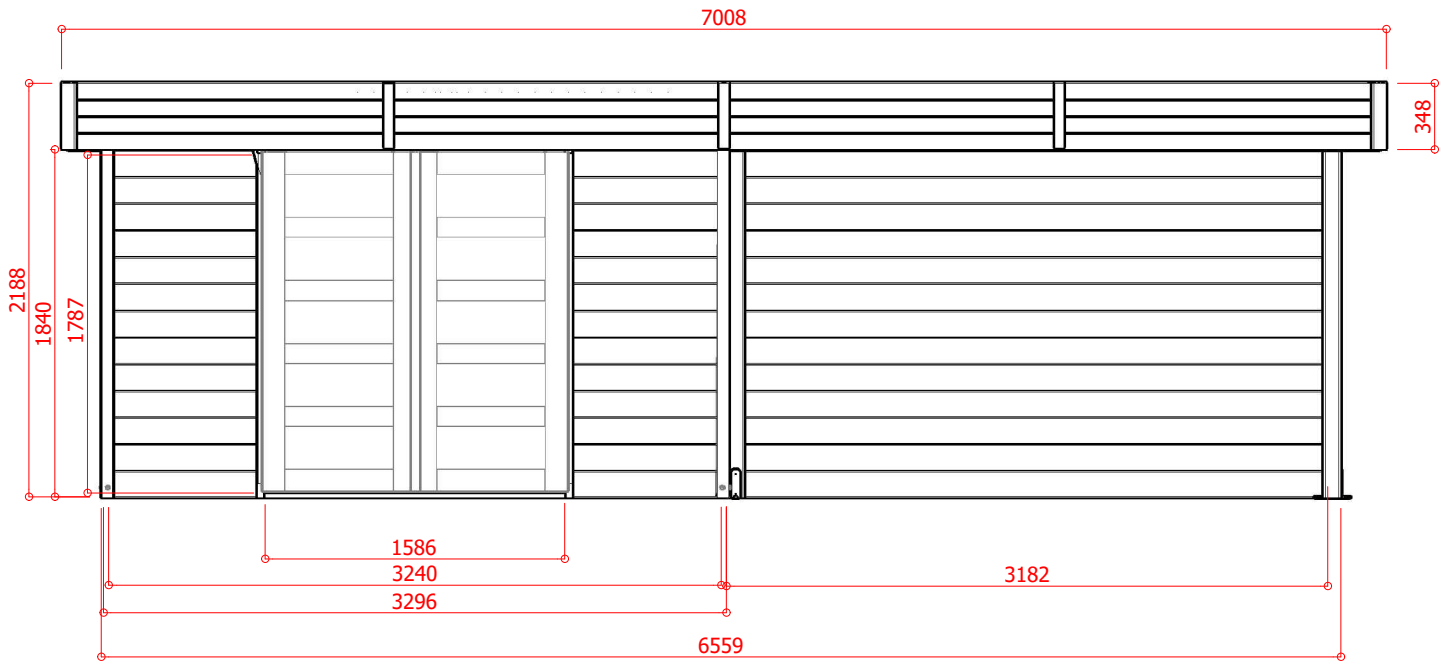

- (GB) After sales service
- (NL) Dienst na verkoop
- (F) Service après vente
- (D) Kundendienst

# S8387



	<b>7.65</b> m <sup>2</sup>
	<b>19.67</b> m <sup>2</sup>

Schaal / Échelle / Scale / Escala / Escala / Scala : 1:40

Dakhelling ± 3 °	Pendente ± 3 °
Pente ± 3 °	Pendiente ± 3 °
Gradient ± 3 °	Pendenza ± 3 °

Industriepark 8  
8587 Spiere-Helkijn

CreateDate: 22.11.2019  
SaveDate: 22.11.2019  
PlotDate: 22.11.2019

Deuropening / Embrasure de porte / Doorway /  
Apertura de puerta / Apertura delle porte / Abertura de portas

Breedte / Largeur / Width / Anchura / Boca / Larghezza	1640
Hoogte / Hauteur / Height / Altura / Altezza / Altura	1710

# S8387

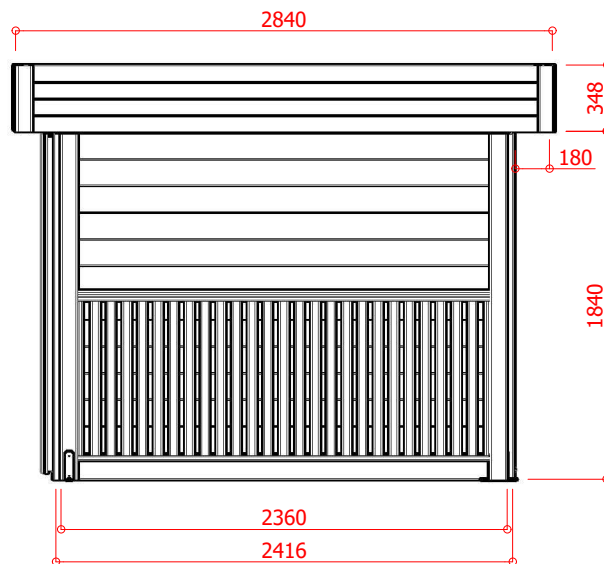
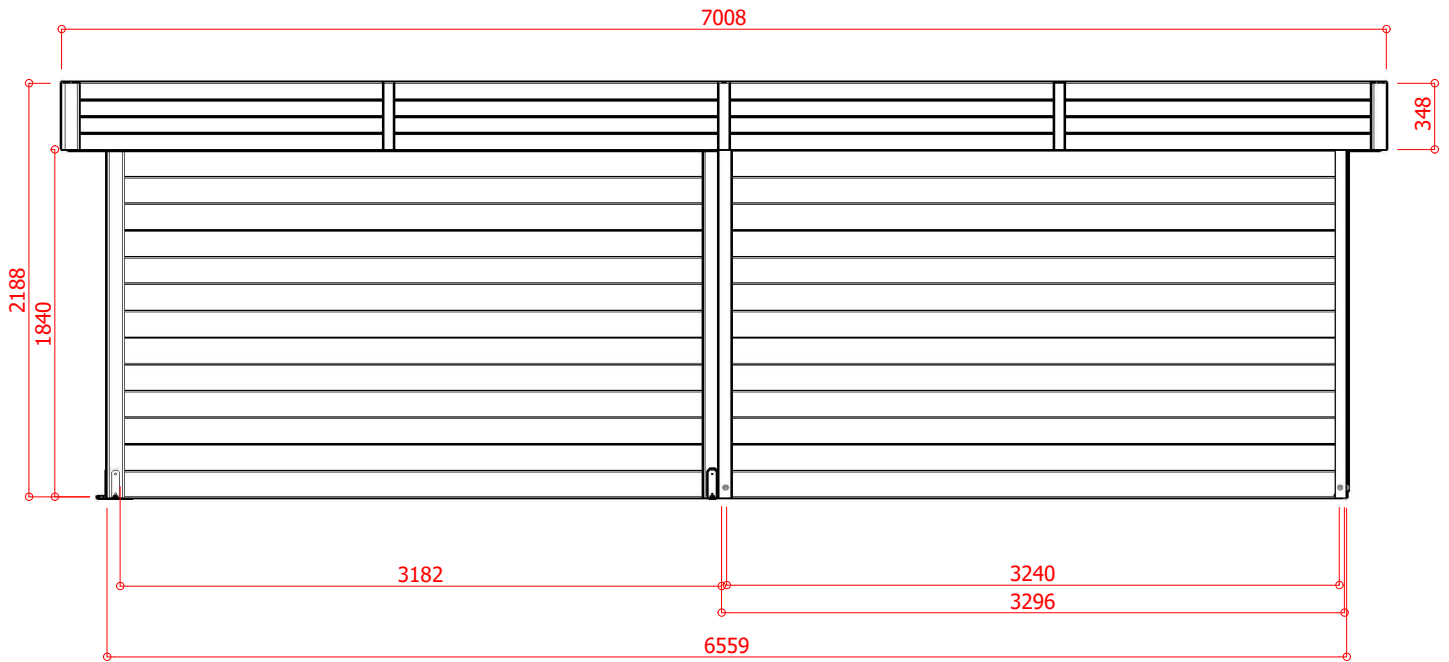

Industriepark 8  
8587 Spiere-Helkijn

CreateDate: 22.11.2019  
SaveDate: 22.11.2019  
PlotDate: 22.11.2019

	Ref.		Index	#
	A	WW028x149-TPP-TSG-0-	2380	1
	A1	WW028x149-TPP-TSD-0-	2380	1
	A2	WW028x149-TPP-TS0-0-	2380	1
	B	WW028x149-1IF-TS2-0-	822	13
	C	WW028x149-1IF-TS1-0-	822	13
	D	WW028x149-1IF-TS0-0-	198	1
	D1	WW028x141-1IF-TS0-0-	198	1
	D2	WW028x141-1IF-TS0-0-	198	1
	D3	WW028x149-1IF-TS0-0-	198	1
	E	WW028x149-2IF-TS0-0-	2380	26
	F	WW028x149-AV1-TS1-0-	3260	1
	F1	WW028x141-AV1-TS1-0-	3260	1
	F2	WW028x141-AV1-TS1-0-	3260	1
	F3	WW028x149-AV1-TS3-0-	3468	1
	F4	WW028x141-AV1-TS3-0-	3468	1
	F5	WW028x141-AV1-TS3-0-	3468	1
	F6	WW028x149-AV1-TS3-0-	3468	1
	G	WW028x149-2IF-TS0-0-	3280	13
	G1	WW028x149-PRF-000-0-	3090	13
	G2	WW028x070-FEM-000-0-	3090	1
	H	WW058x90-B2M-TS0-0-	3336	1
	J	WW016x095-PLA-000-0-	2695	81
	K	WW040x120-1IF-IF1-0-	3530	2
	K1	WW040x120-4FA-000-0-	180	17
	L	WW016x040-4FA-000-0-	2695	12
	M	WW016x087-PLA-000-0-	3490	4
	M1	WW016x095-PLA-000-0-	3490	8
	M2	WW016x095-2R8-RAI-0-	3490	4
	M3	WW016x087-2R8-PLA-0-	2776	2
	M4	WW016x095-4FA-000-0-	2776	4
	M5	WW016x095-4FA-000-0-	2776	2
	N1	WW016x072-2R8-PLA-0-	348	10
	N2	WW016x072-2R8-PLA-0-	348	4
	S1	WW016x90-PLA-000-0-	3336	1
		S678-R-ASK		4

## S8387

## PO

Winkel / Magasin / Store / :

Klant / Cliënt / Client / :  
Adres:

Verantwoordelijke / Responsable

CreateDate: 22.11.2019  
SaveDate: 22.11.2019  
PlotDate: 22.11.2019



	Ref.	L	Index	#
	V 80 x 72 x 2085		1	
	V1 80 x 72 x 2085		1	
	V2 80 x 72 x 1944		1	
	V3 80 x 72 x 1944		1	
	T WW090x090-4R8-PE0-0-	1944	2	
	T1 WW090x090-4R8-PE0-0-	2085	1	
	T3 S5501		3	
	S6477		2	
	Z S5621 S8053		1	
	P + P1R (40 x 55 x 1838) + S676 F40 (1) + P1L (40 x 55 x 1838) + S677 (2) + P2 (70 x 55 x 1676) + S6861 (3) + P3 (16 x 30 x 1790) + S8094ALU (ALU 20x60x1586) + S8108-G (249x650 #10)		1	
	O S504 Roofing 7.2 m		3	
	M6 x 40 (16)			
	M6 x 60 (3)			
	M8 x 50 (2)			
	M8 x 110 (6)			
	M6 (21)			
	M8 (6)			
	M8 (2)			
	M8 (6)			
	3 x 30 (80)			
	3 x 40 (18)			
	3 x 50 (6)			
	3 x 70 (4)			
	4 x 16 (8)			
	4 x 70 (2)			
	5 x 90 (44)			
	4 (2)			
	2.5 x 40 (199)			
	2.5 x 16 (300)		1	

## S8387

## PO \_\_\_\_\_

Winkel / Magasin / Store / :

Klant / Cliënt / Client / :  
Adres:

Verantwoordelijke / Responsable



# S8387

B = 1  
C = 1  
E = 2  
G = 1

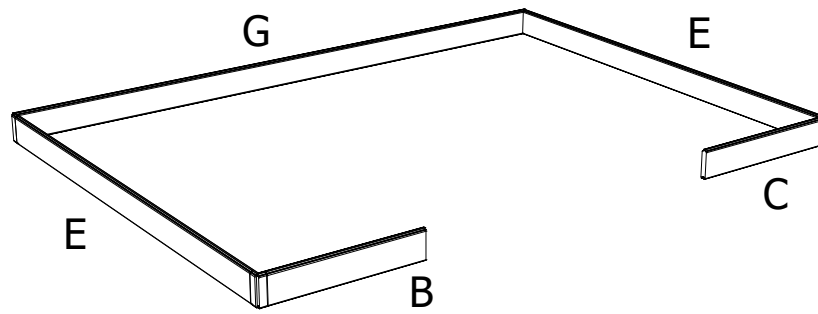

1

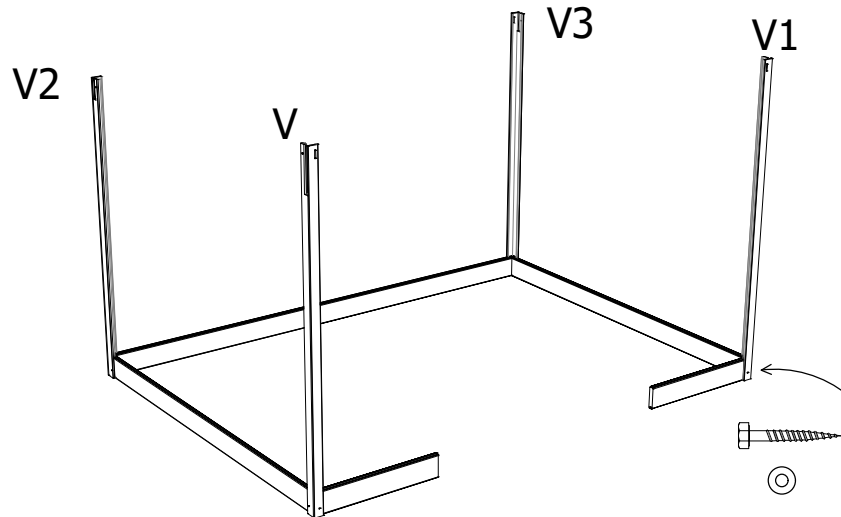
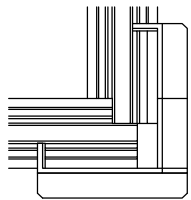

V = 1  
V1 = 1  
V2 = 1  
V3 = 1

2

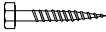

 M6 x 40 - 8#  
 M6 - 8#

B = 12  
C = 12  
E = 24  
G = 12

3

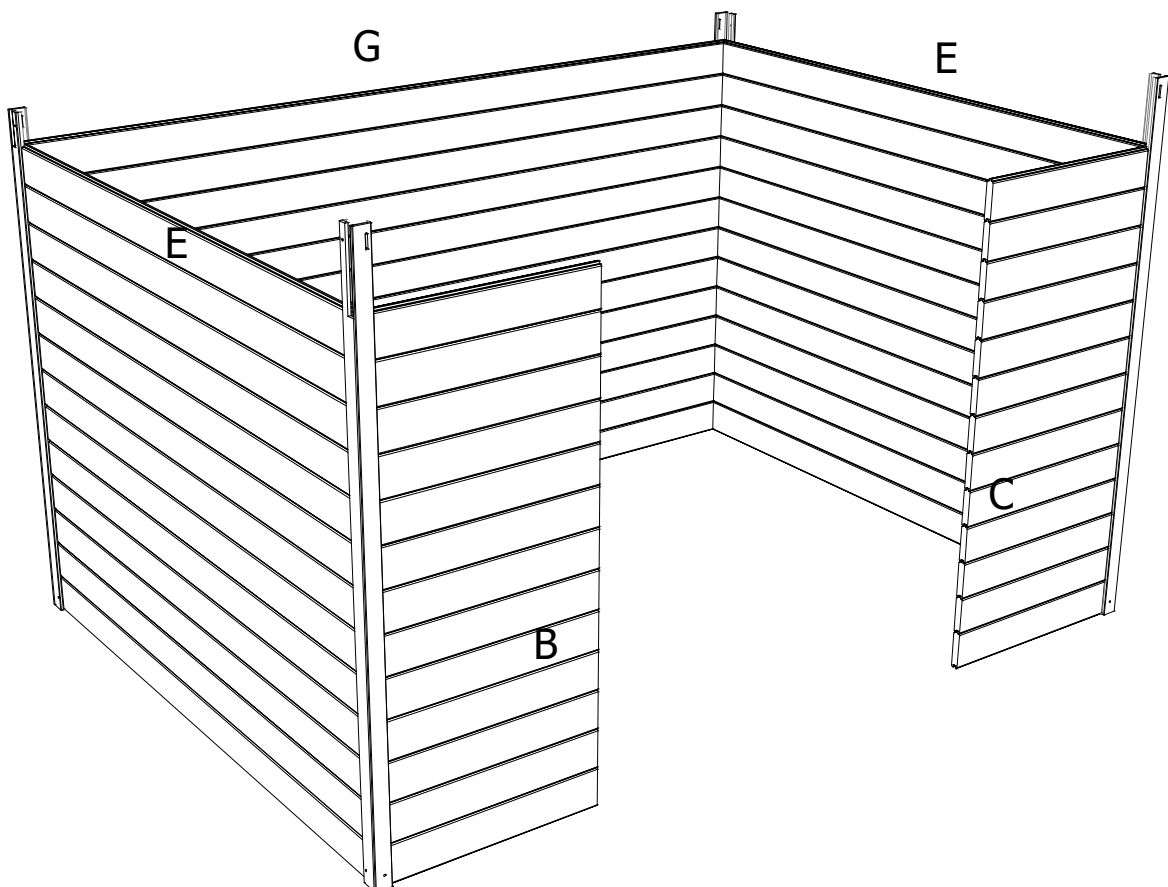

# S8387

H = 1

4

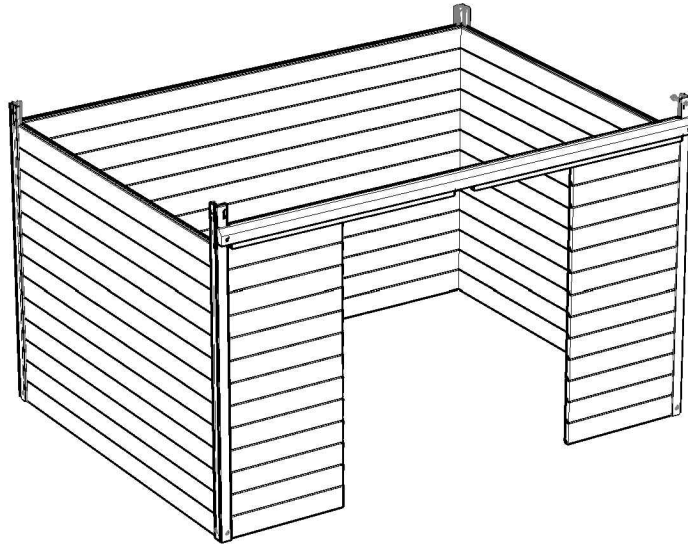

M8 x 50 #2

M8 #2

M8 #2

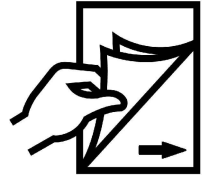

A1 = 1

A2 = 1

A3 = 1

D = 1

D1 = 1

D2 = 1

F = 1

F1 = 1

F2 = 1

F3 = 1

F4 = 1

F5 = 1

T = 2

T1 = 1

T3 = 2

M6 x 40 (8)

M6 #8

5

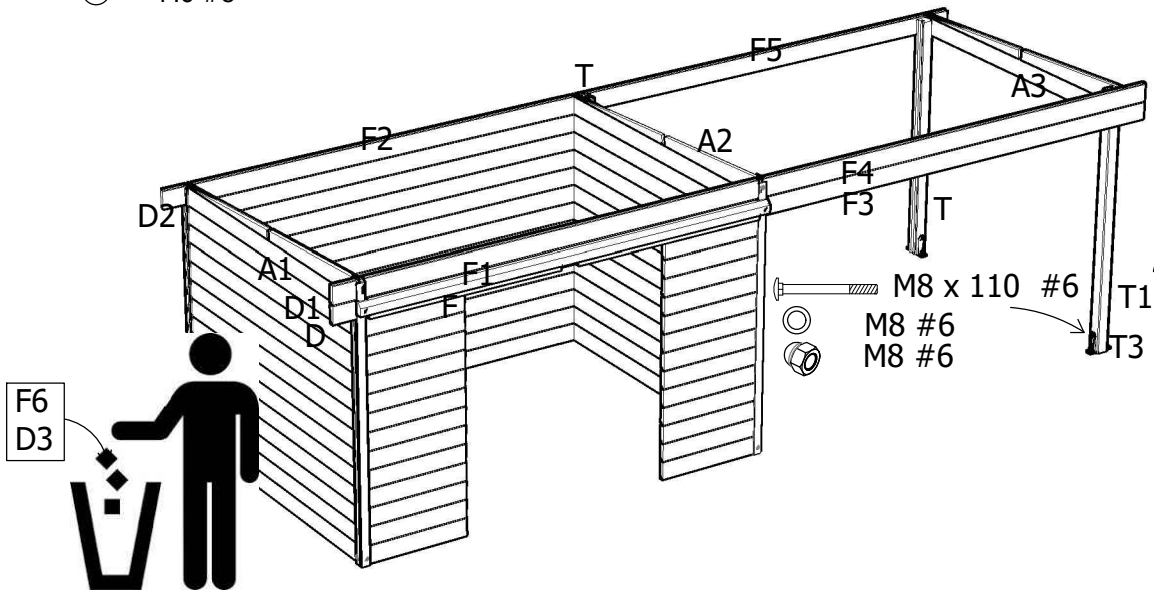

M8 x 110 #6

M8 #6

M8 #6

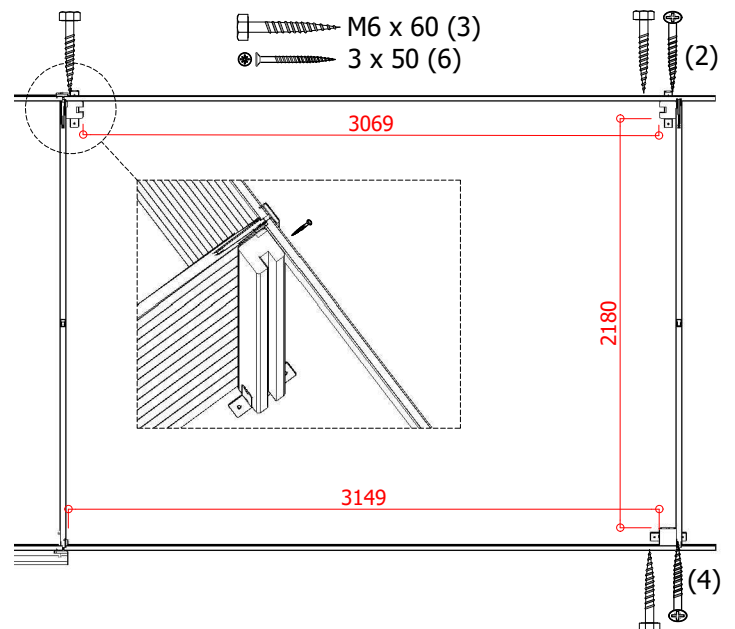
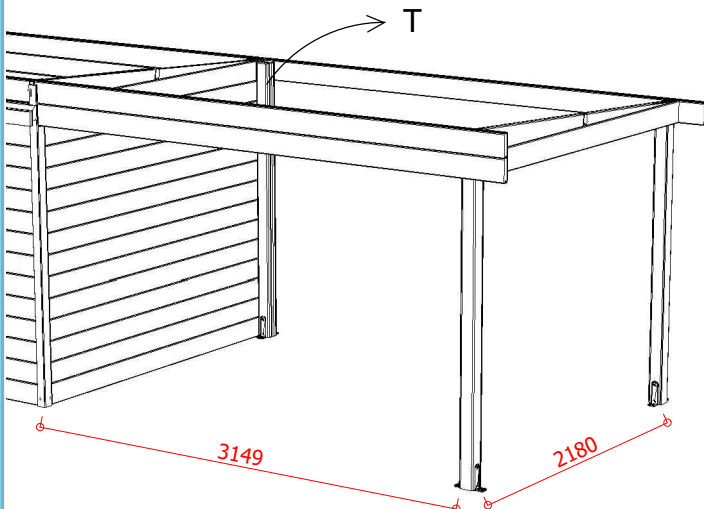

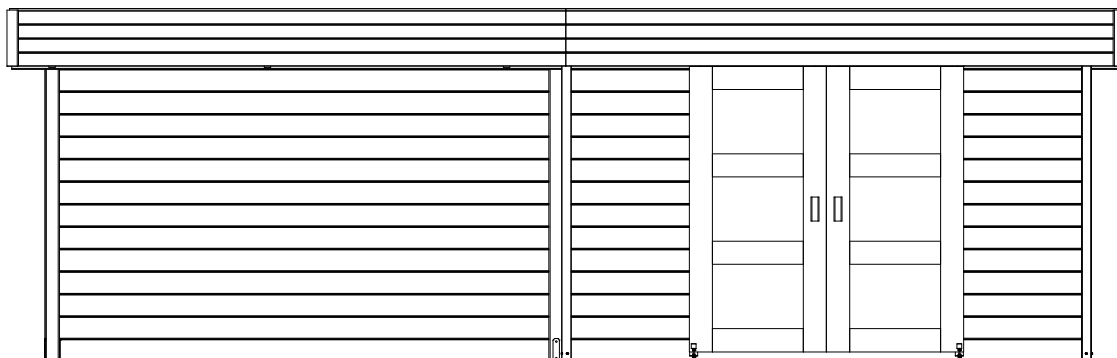
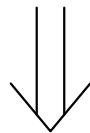
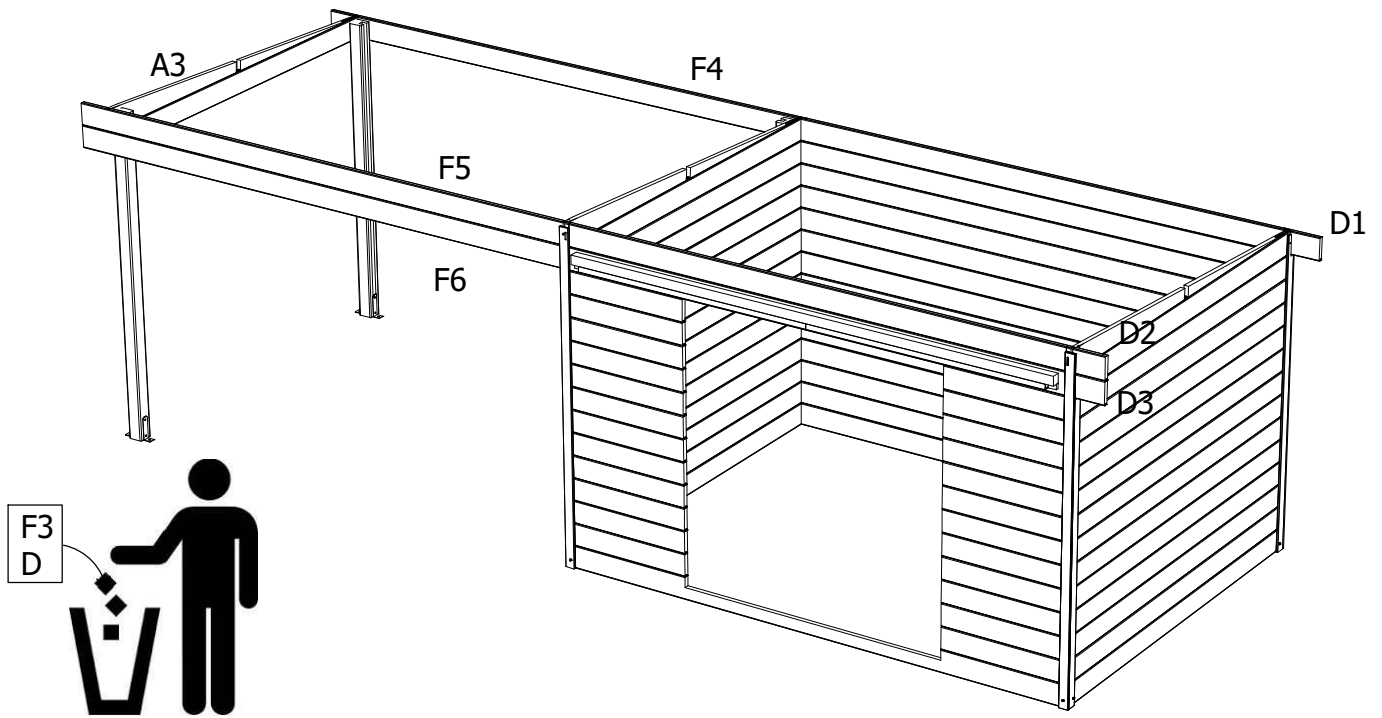



# S8387

K = 2

G1 = 13

G2 = 1

6

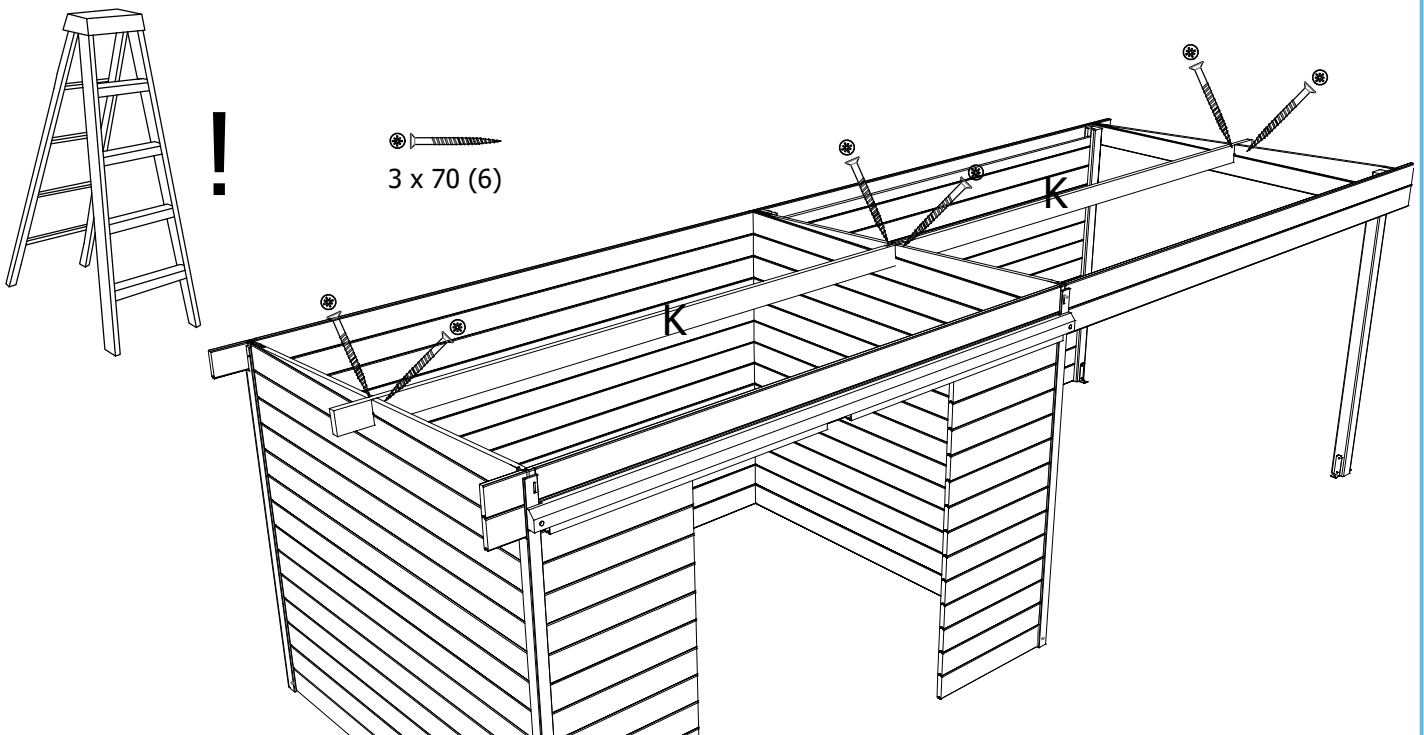
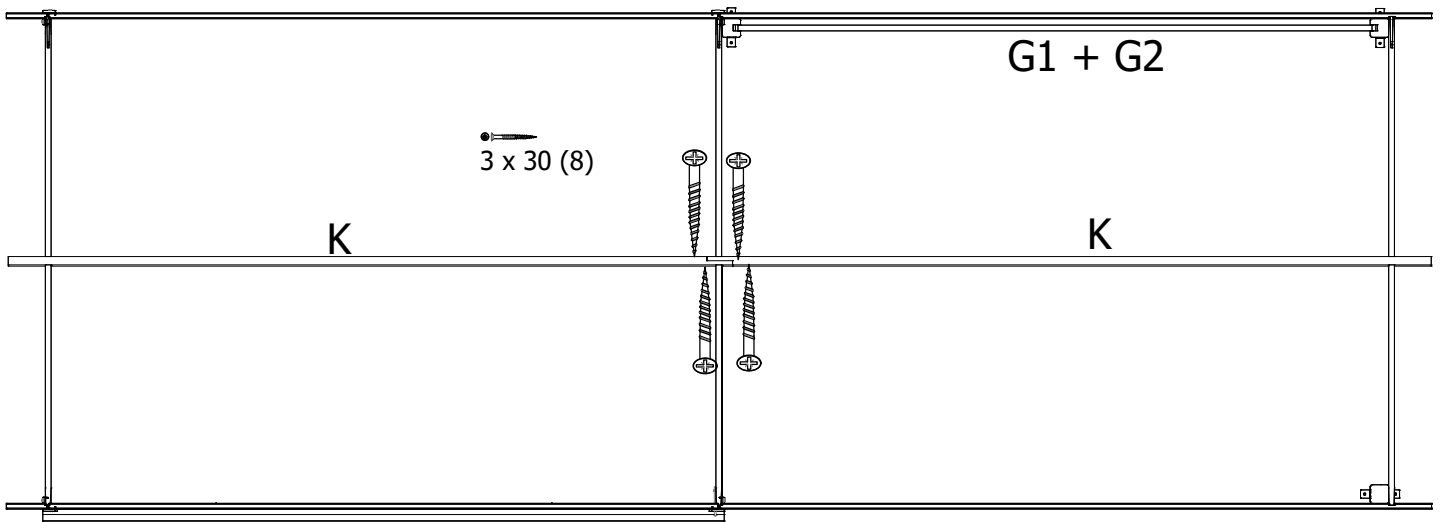
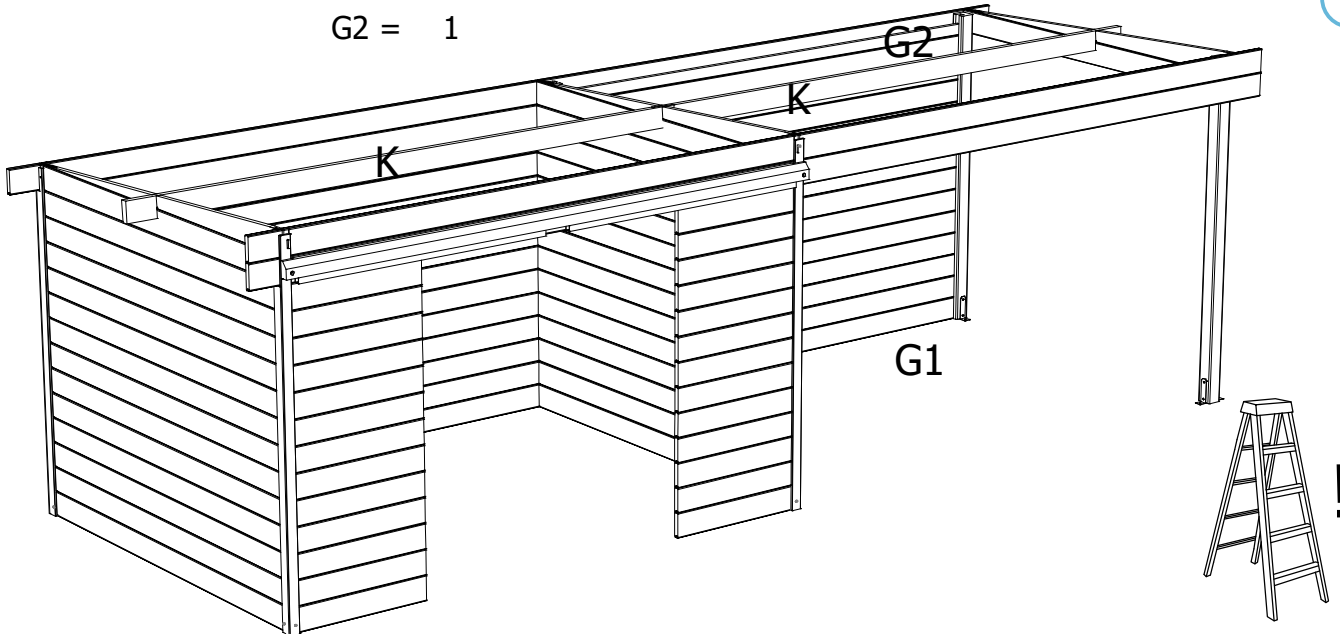

# S8387

P1R = 1  
P1L = 1  
P2 = 2

3 x 40 (6)

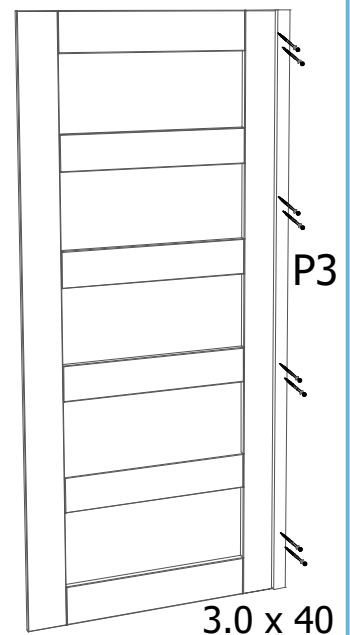
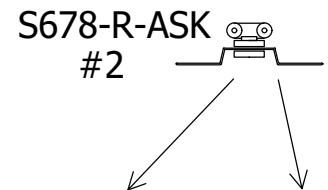
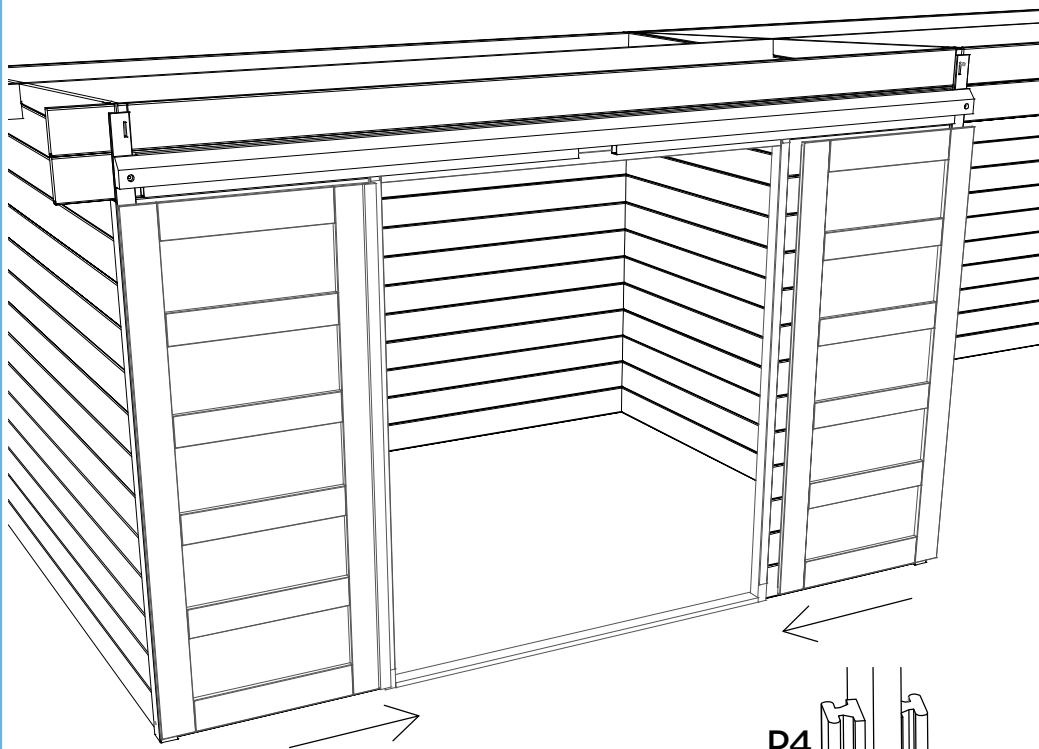
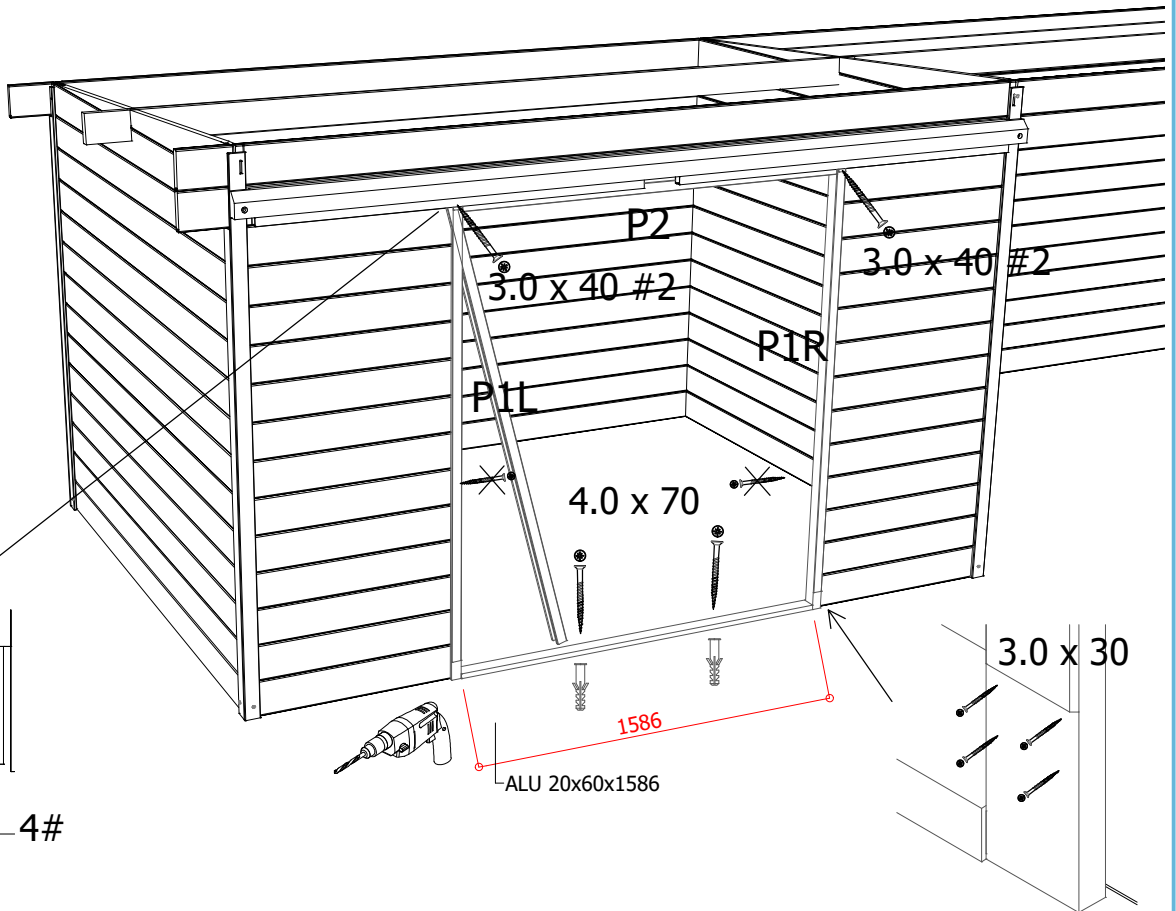
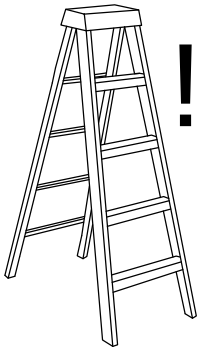

- 3.0x30 - 8#
- 3.0x40 - 8#
- 4.0x16 - 8#
- 4.0x70 - 2#
- 5 x 90 (4)
- 5.0x90 - 8#
- 2#

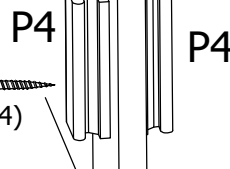

K1 = 17

8

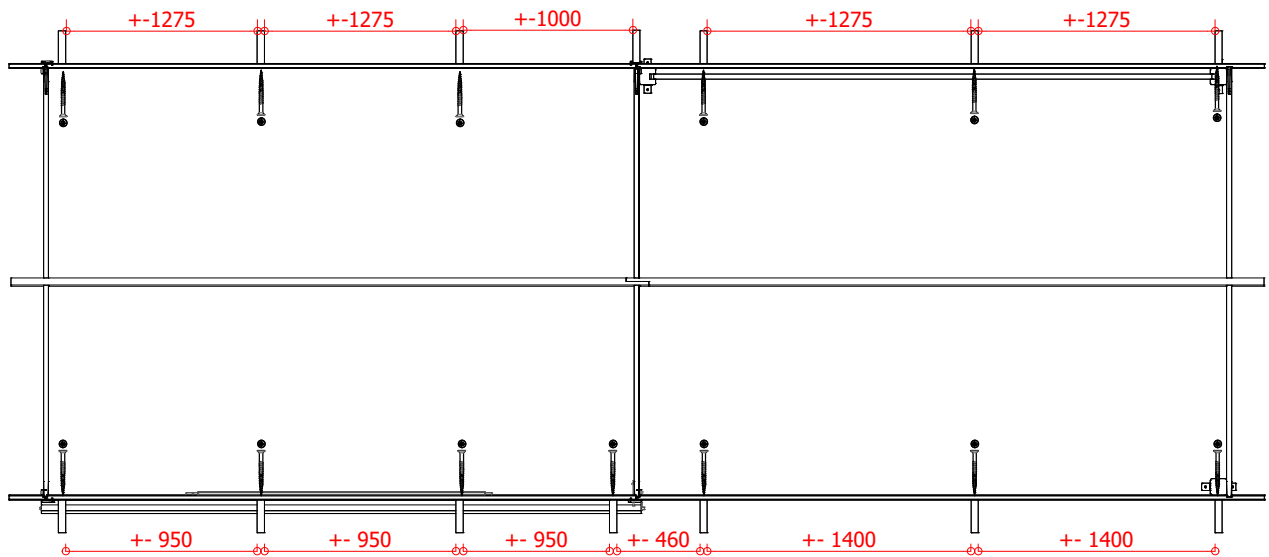
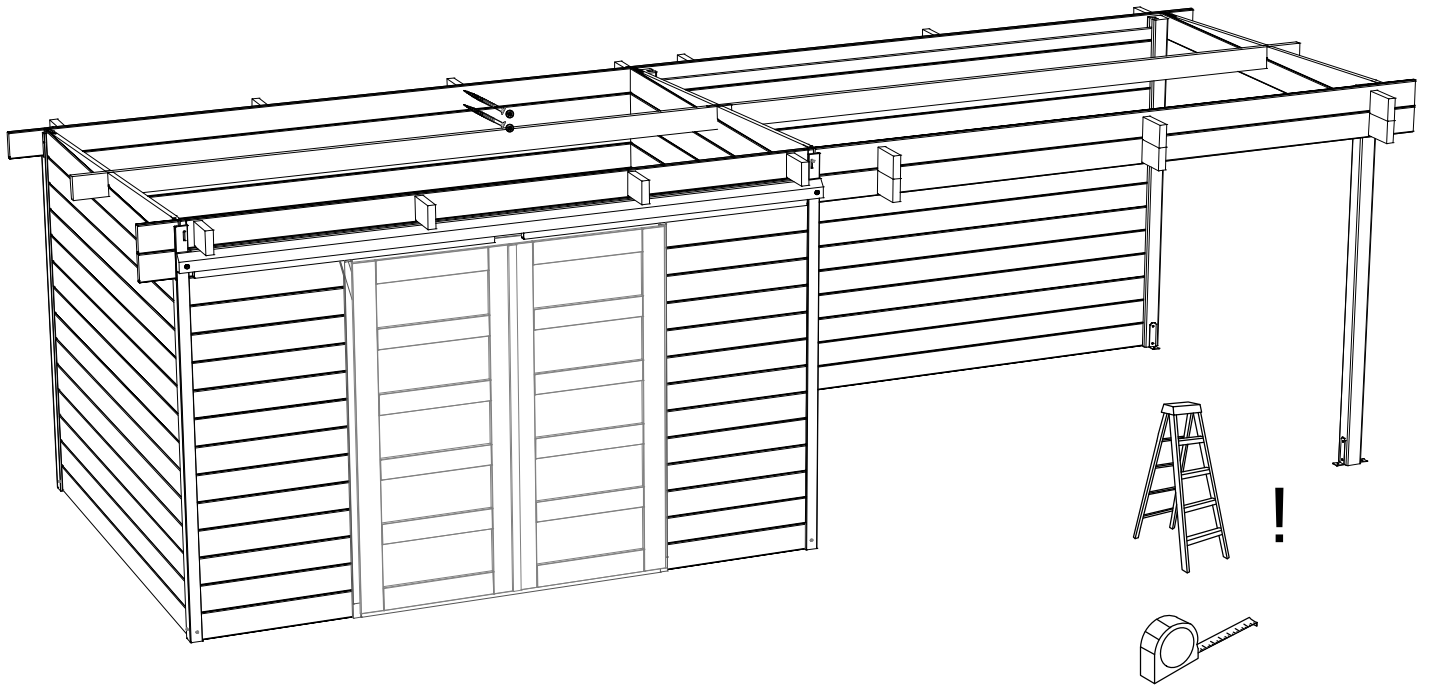

J = 81

S1 = 1

2.5 x 40 (250)

5 x 90 (36)

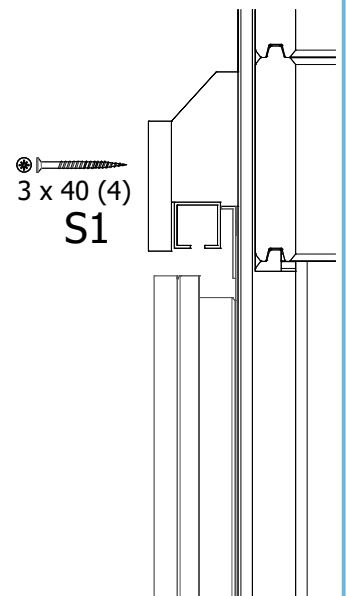
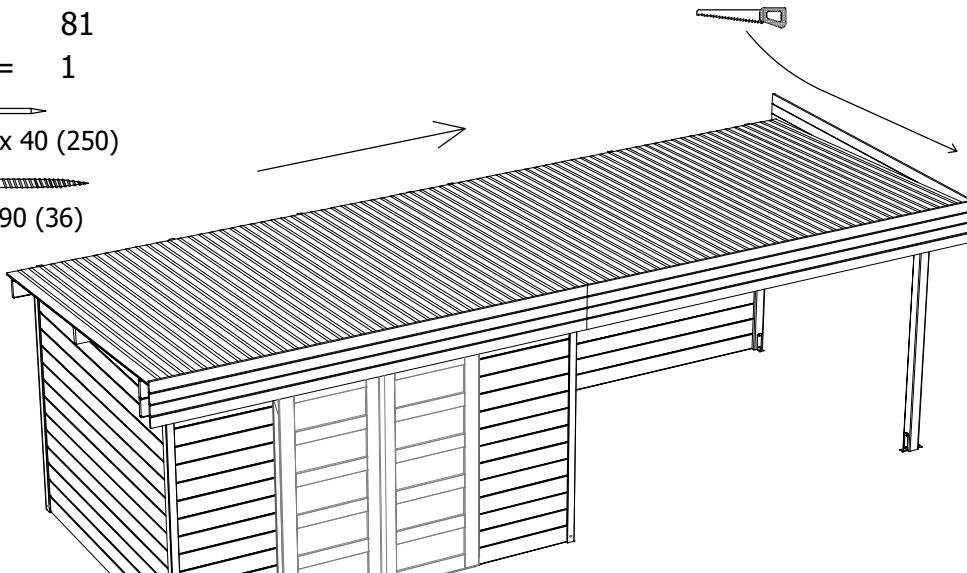

# S8387

- M = 4
- M1 = 8
- M2 = 4
- M3 = 2
- M4 = 4
- M5 = 2

9

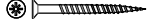
 3 x 30 (28 + 8)

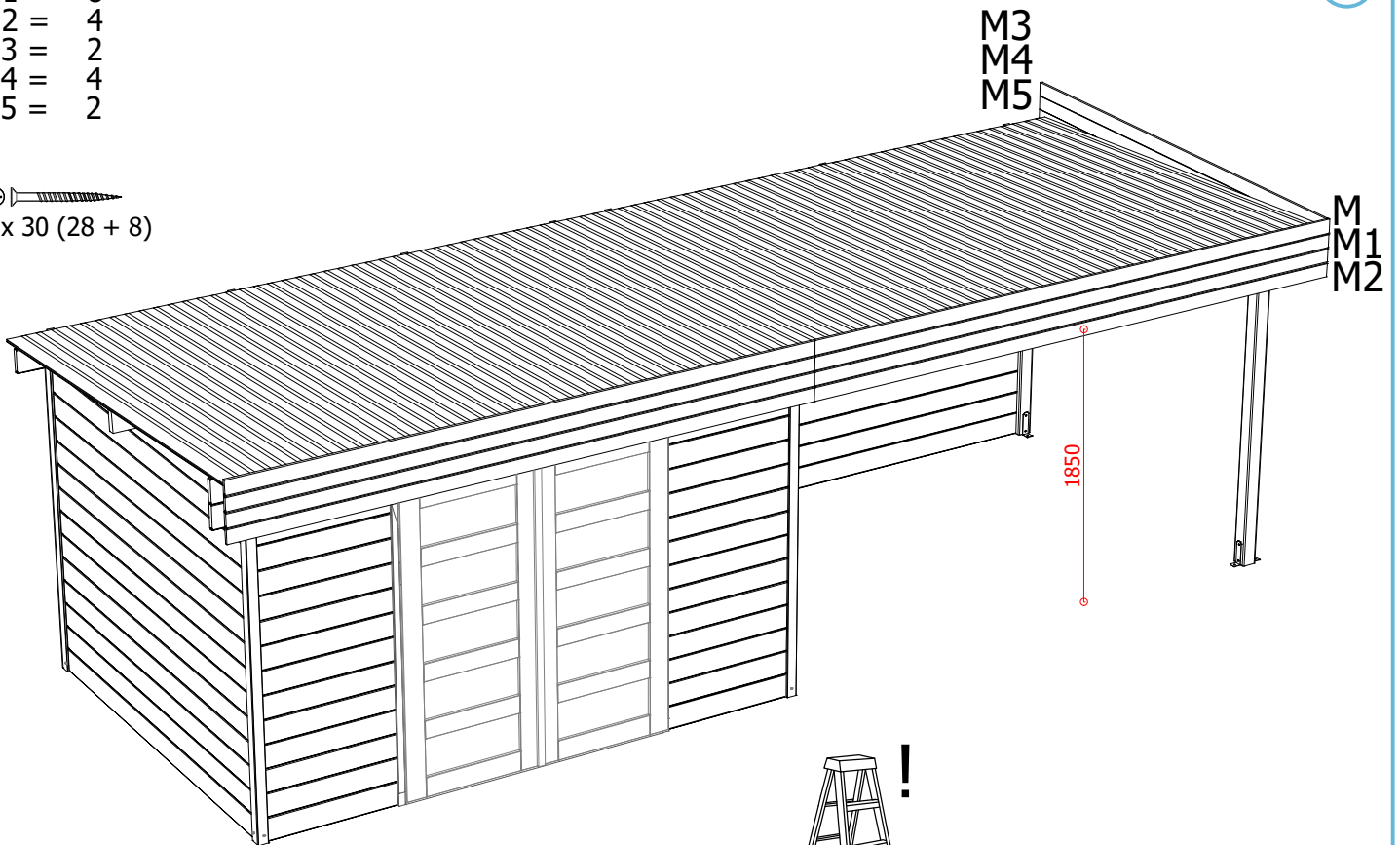

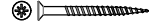
 3 x 30 (28 + 8)

10

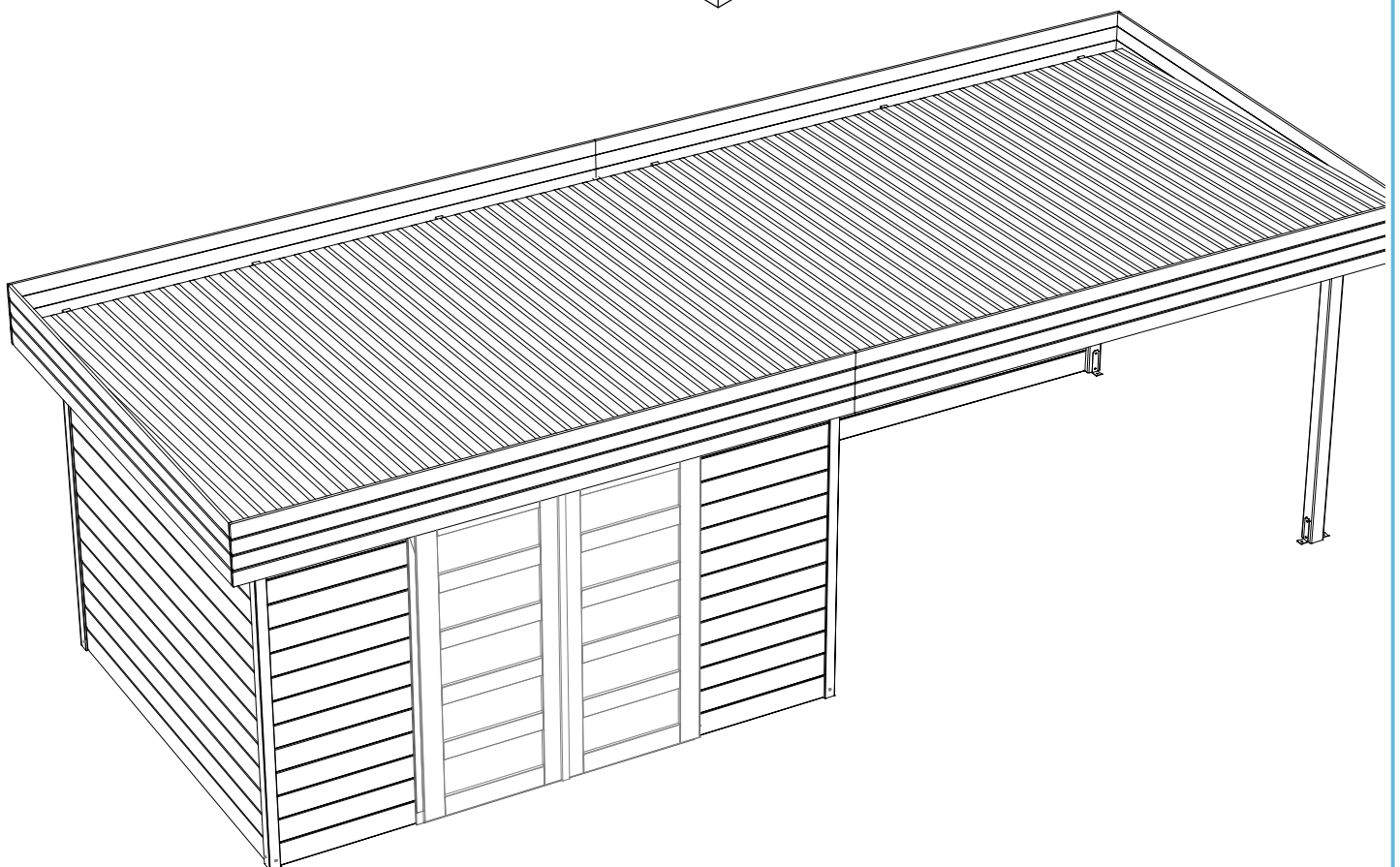
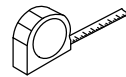

# S8387

O = 3 x 7000

#300

11

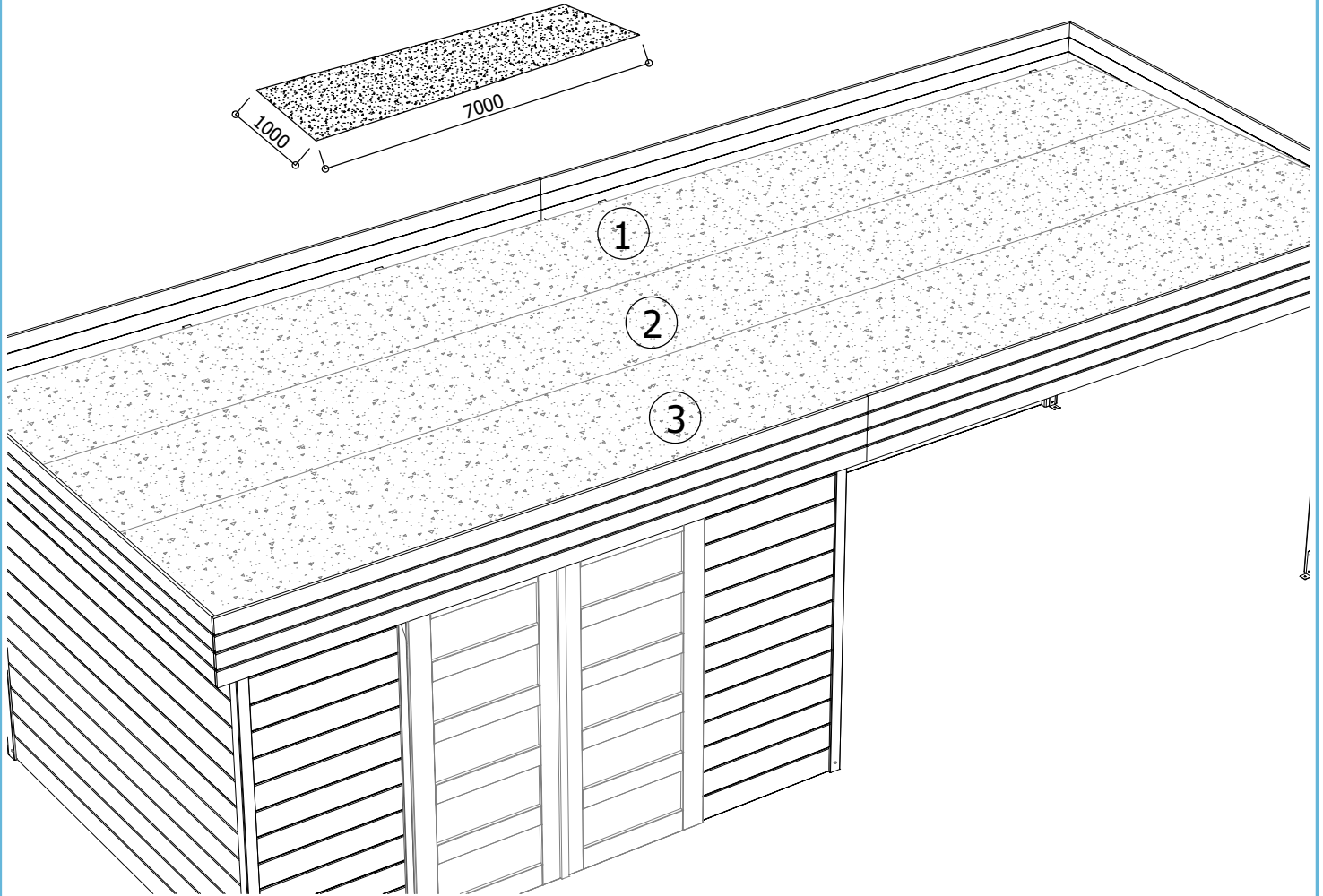

L = 12 2.5 x 40 (50)

N1 = 10  
N2 = 4 3 x 30 (42)

12

